

CMP Installation Guide





Preface

This instruction book is for your crews. Distribute it to help them install Contech® corrugated metal pipe (CMP) correctly. Proper installation of a flexible CMP culvert and storm drain systems will ensure long-term performance. CMP culverts and storm drains are typically of a single round or single pipe arch in an embankment or trench condition. However, it is not uncommon to install multi-barrel systems to meet the site-specific hydraulic conditions. Therefore, as the pipe diameter becomes larger or has multiple barrels the installation often requires special construction practices that differ from conventional small diameter (i.e. < 48" diameter) trench condition flexible pipe installation. Contech strongly suggests scheduling a pre-construction meeting with your local Sales Engineer to determine if additional measures, not covered in this guide, are appropriate for your site. All OSHA and local safety guidelines should be observed during the construction of the system and site.

Don't assume experienced workers know all the answers. Review these instructions with your supervisors and crews. It can mean a safer and better job for you and your customer. We recommend holding a preconstruction meeting with your Contech representative and all interested parties to ensure everyone involved in your project has a high level of understanding on what means and methods will be used to prepare for, install and grout the new structure(s). If you have any questions about these instructions, call your Contech Representative.

Contents	Page
Unloading and Safety Instructions	3
Foundation and Pipe Bedding	5
Connecting Bands	6
In Situ Trench Wall	8
Backfill Material	8
Backfill Placement	9
Backfill Placement for Multiple Barrels	10
Final Cover Placement and Construction Loading	11
Manhole Risers	12
Pipe End Treatment	14
Skewed Ends	15

TERMS YOU SHOULD KNOW

WARNING

Alerts you to hazards or unsafe practices that CAN result in severe personal injury or property damage.

SAFETY INSTRUCTIONS

Messages about procedures or actions that must be followed for safe handling and installation of CMP Pipe. Failure to follow these instructions can result in serious injury or death and/or damage to the pipe.





Unloading and Handling

The following equipment is recommended for unloading pipe or pipe bundles:

- Forklift
- Front-end loader with fork adapters
- Backhoe with fork adapters
- Cranes
- Non-metallic slings

Other unloading methods such as lifting lugs, chains, wire rope, cinching or hooks in the end of the pipe should not be used.

Safety Instructions

1. Only trained and authorized equipment operators are to be permitted to unload the trailer.
2. Wear approved safety hat and shoes, gloves and eye protection.
3.  **Pipe ends may be sharp. Workers handling pipe must wear gloves made from cut-resistant materials.**
4. Park the truck and trailer on level ground before you start unloading. It is the responsibility of the consignee to direct the driver to level ground for parking the truck.
5. Keep all unauthorized persons clear of the area when the driver releases the binders from the trailer and during unloading.
6.  **Sometimes pipes are bundled together on the truck with steel straps. Do not cut the steel strapping around the bundles until the bundles have been placed on level ground, blocked or secured, and will not be moved again as a unit. It is recommended that the steel strapping be cut with appropriate sized cutting tools. Stand to the side when cutting a strap. Always be aware that pipe may move, roll or fall when a strap is cut.**
7.  **Do not lift bundles or sections of pipe by the steel strapping around the bundles.**
8. Know the capabilities and rated load capacities of your lifting equipment. Never exceed them.
9.  **Do not stand or ride on the load of pipe while it is being unloaded. Do not stand beneath or near the pipe while it is being unloaded.**
10. If unloading at multiple drop-off points, secure the remaining load and pallets between drop off points. Always unload the top pallets or bundles first.
11. The contractor shall be responsible for the safety of his/her employees and agents. Adequate safety indoctrination is his responsibility and shall be given to all personnel employed by his firm.
12. Safe practices on construction work as outlined in the latest edition of the "Manual of Accident Prevention in Construction," published by the Associated General Contractors, shall be used as a guide and observed.
13. The contractor shall comply with all applicable city, state, and federal safety codes in effect in the area where he is performing the work. This conformance shall include the provisions of the current issue of the "OSHA Safety and Health Standards (29 CFR 1926/1910)" as published by the U.S. Department of Labor.

Proper Pipe Unloading, Handling & Placement

The pipe should be unloaded off the flatbed trailer with a forklift, excavator, crane or other piece of construction equipment. The pipe should never be dropped or pushed off the flatbed trailer. Nylon slings may wrap around the pipe or steel chains may be used to connect to pipe attached lifting lugs for both unloading and placement of the pipe sections.

Pipe installation typically starts at the downstream end and progresses upstream. Sometimes the pipe is lettered or numbered to show which pipe ends should be connected. This is called match marking the ends.



Lifting CMP off the flatbed with a front end loader and forks



Lifting Aluminized Type 2 (ALT2) CMP with nylon slings



Lifting CMP utilizing factory attached lifting lugs



Lifting polymer-coated CMP with nylon straps

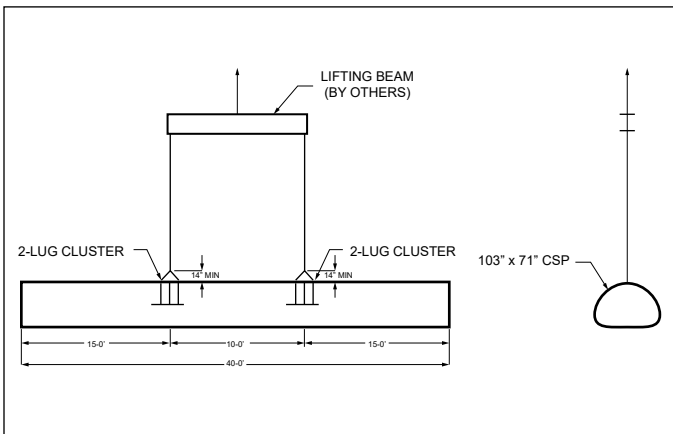

A spreader bar can be used for heavier and long length pipe.



Spreader bar used to lift CMP custom fitting.

Foundation and Pipe Bedding

Construct a foundation that can support the design loading applied by the pipe and adjacent backfill weight as well as maintain its integrity during construction. If soft or unsuitable soils are encountered, remove the poor soils to a suitable depth and then replace with a competent granular material to the appropriate elevation. The granular material gradation should not allow the migration of fines, which can cause settlement of the pipe system or pavement above. If the structural fill material is not compatible with the underlying soils a geotextile fabric should be used as a separator.

Grade the foundation subgrade to a uniform or slightly sloping grade. If the subgrade is clay or relatively non-porous and the construction sequence will last for an extended period, it is best to slope the grade to the outlet end of the system. This will allow excess water to drain quickly, preventing saturation of the subgrade.

A 4" – 6" thick, well-graded granular material is preferred for the pipe bedding. If the existing foundation is made up of a coarse sand or other suitable granular material, imported bedding material may not be required.

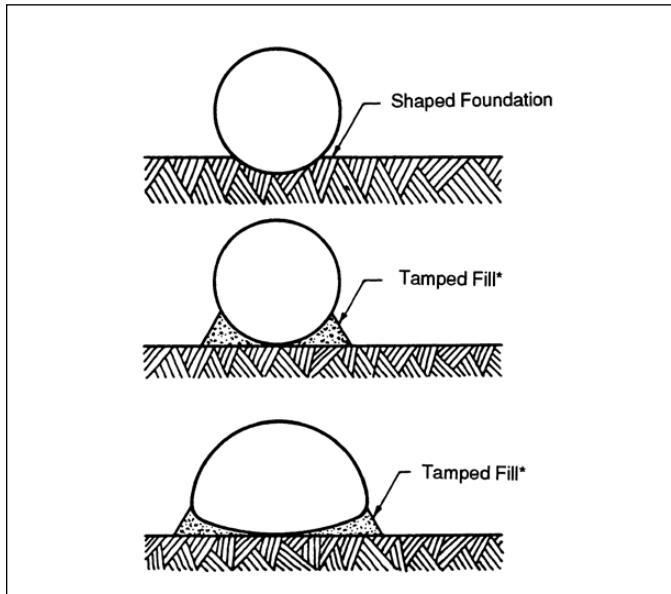

Methods for attaining proper compaction under haunches of CMP and pipe-arch.

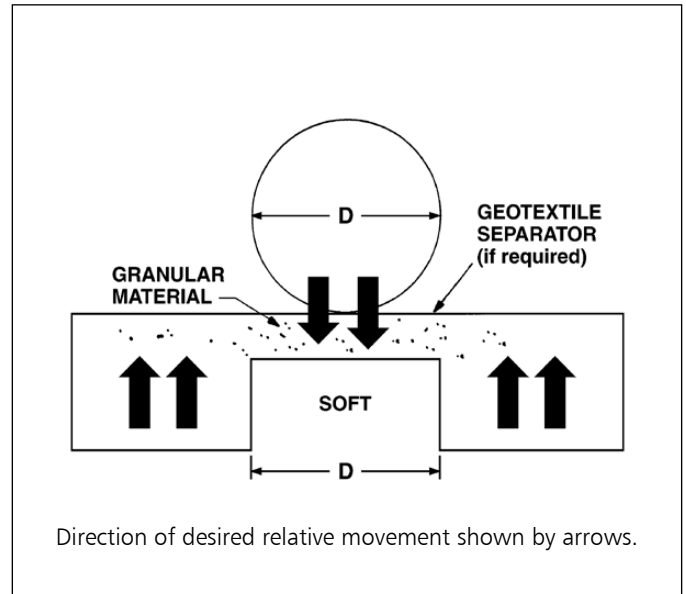

Treatment for Soft Foundations



Typical storm sewer with 4" – 6" of import granular material as pipe bedding.



Culvert foundation required undercutting and importing 18" of granular fill for pipe bedding.

Connecting Bands

There are various types of connecting bands for connecting CMP. HUGGER® bands and corrugated bands are the most common. Flat gaskets or O-ring gaskets can also be used in conjunction with connecting bands to reduce leakage in the joints



Installing a HUGGER® band on a perforated CMP



Tightening bolts on a corrugated band.



Placement of flat neoprene basket on end of CMP

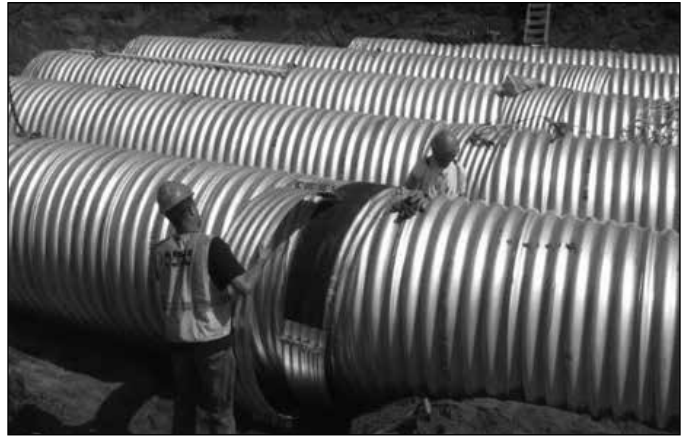

Installation of corrugated band with flat neoprene gasket

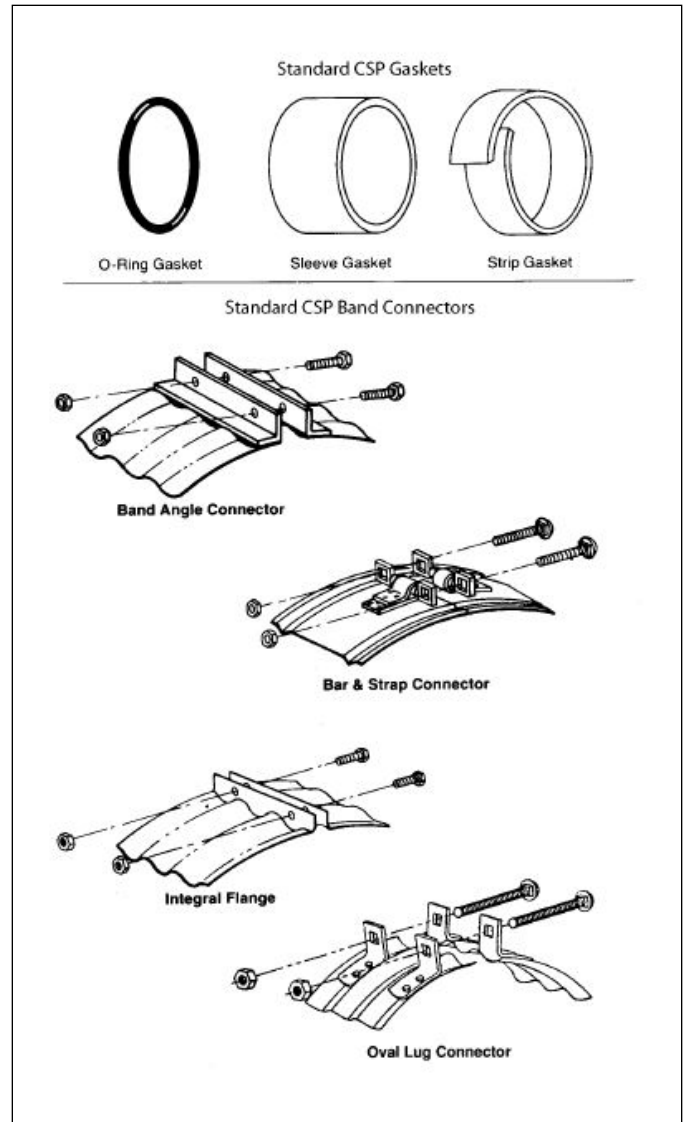
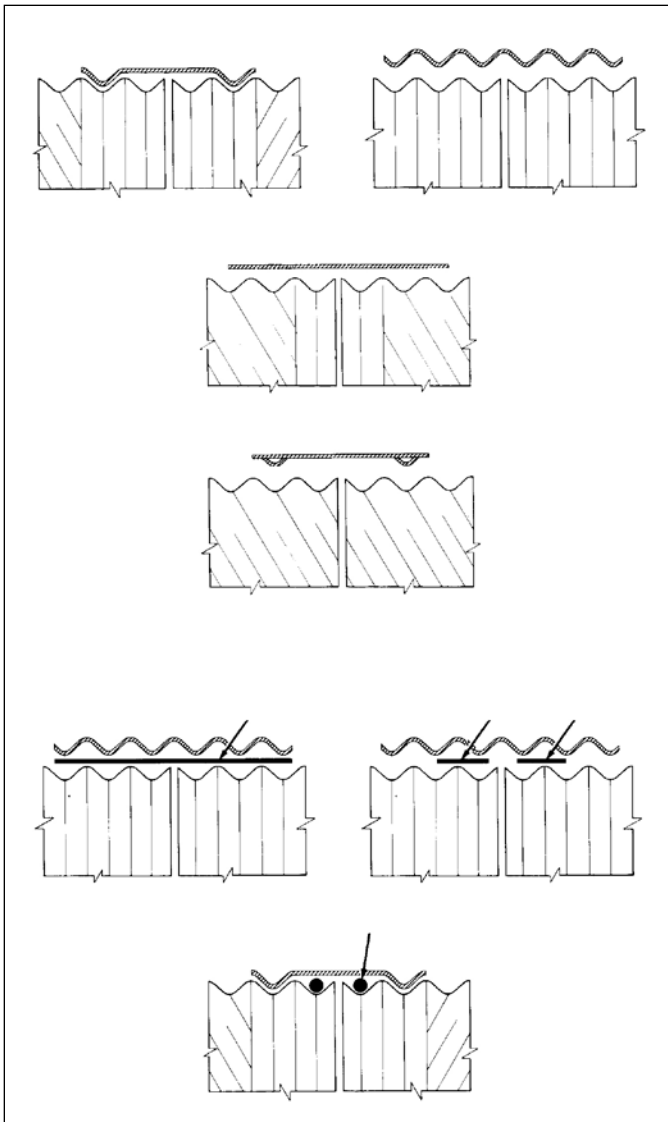

Some jobs may require special bands, such as rod and lug connection, flat bands, or dimple bands.

In-Situ Trench Wall

If excavation is required, the trench wall needs to be capable of supporting the radial loads that the pipe generates as the system is loaded. If soils are not capable of supporting these loads, the pipe can deflect. Perform a simple soil pressure check using the applied loads to determine the limits of excavation beyond the spring line of the outer most pipes.

In most cases, the trench width requirements for a safe work environment and proper backfill placement and compaction take care of the concern.



Backfill Material

Corrugated Metal Pipe is a flexible pipe. All buried flexible pipes are dependent on a quality backfill material for structural support. AASHTO refers to these pipe systems as, "Soil-Corrugated Metal Structure Interaction Systems". During placement of backfill and cover the pipe will slightly deflect under load (<2% optimal). When this occurs the pipe wall goes into Ring Compression and the backfill over the pipe forms a soil arch helping to distribute the load onto side backfill of the pipe or multiple barrel pipes. Therefore, compaction in equal lifts on either side of the pipe is so important.

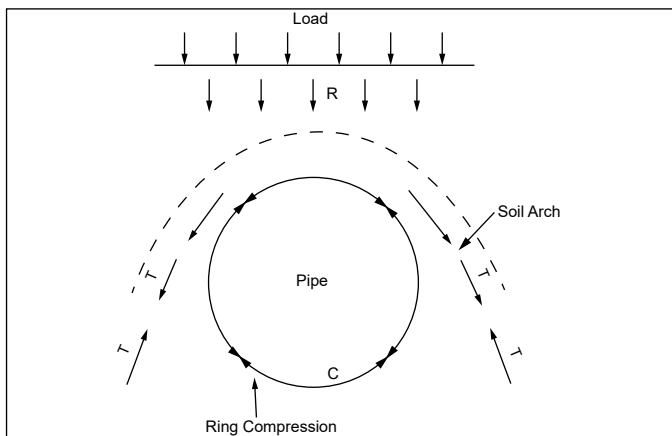
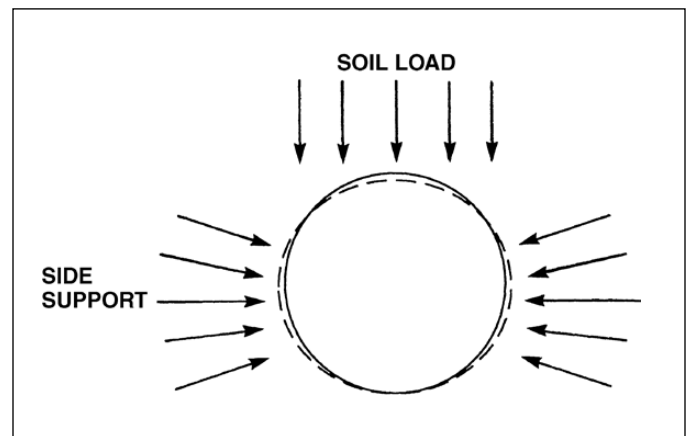

Diagram showing how load P_v is partly carried by means of a soil arch over the pipe.



Pipe side support is developed by slight pipe deflection under load.

The best backfill material is an angular, well-graded, granular fill meeting the requirements of AASHTO A-1, A-2, or A-3. Aggregate materials that are free draining and compact easily such as crushed aggregate, crushed aggregate with fines, gravely sand, and coarse sand make good backfill. The aggregate particle size shall not exceed 3" in diameter.

For solid pipe, well graded or open graded granular material can be used as backfill. Infiltration pipe systems have a pipe perforation sized of 3/8" diameter. An open graded stone, with a particle size of 1/2" – 2 1/2" diameter is recommended for backfill around perforated pipe.

Backfill using controlled low-strength material (CLSM, "flash fill", or "flowable fill") when the spacing between the pipes will not allow for placement and adequate compaction of the backfill. Below are examples of acceptable backfill materials

Examples of Acceptable Backfill Material



Coarse Sand



Crushed Limestone



Crushed Granite



Crushed River Gravel

Backfill Placement

The backfill shall be placed in 8" +/- loose lifts and compact to 90% AASHTO T99 standard proctor density. Material shall be worked into the pipe haunches by means of shovel-slicing, rodding, vibratory packer, or other effective methods. If AASHTO T99 procedures are determined infeasible by the geotechnical engineer of record, compaction is considered adequate when no further yielding of the material is observed under the compactor, or under foot, and the geotechnical engineer of record (or representative thereof) is satisfied with the level of compaction.

For large systems, conveyor systems, backhoes with long reaches may be used to place backfill. Once minimum cover for the construction loading across the entire width of the system is reached, advance the equipment to the end of the recently placed fill, and begin the sequence again until the system is completely backfilled. This type of construction sequence provides room for stockpiled backfill directly behind the backhoe, as well as the movement of construction traffic. It is important to keep the elevation of backfill between pipes evenly. As a rule of thumb, do not allow for backfill to exceed the elevation of one side of pipe to the other by more than 24".

Material stockpiles on top of the backfilled pipe system should be limited to 9' +/- high and must provide balanced loading across all barrels. To determine the proper minimum cover over the pipes to allow the movement of construction equipment, refer to the Construction Equipment Loading Tables in this guide, or contact your local Contech Sales Engineer.

If CLSM or "flowable fill" is used as backfill, pipe flotation needs to be prevented. Typically, small lifts are placed between the pipes and then allowed to set-up prior to the placement of the next lift. The allowable thickness of the CLSM lift is a function of a proper balance between the uplift force of the CLSM, the opposing weight of the pipe, and the effect of other restraining measures. Your local Sales Engineer can help determine an appropriate lift thickness.

Pipe Arch shapes require special attention. The bedding should be firm, but slightly yielding under the pipe. A vee-shaped bedding for large pipe arched should be considered. Proper care should be given to make sure quality compaction at the haunches of the pipe arch is completed. The haunch area backfill should be a high quality granular aggregate material, compacted to a minimum of 95% to prevent deflection of the pipe.

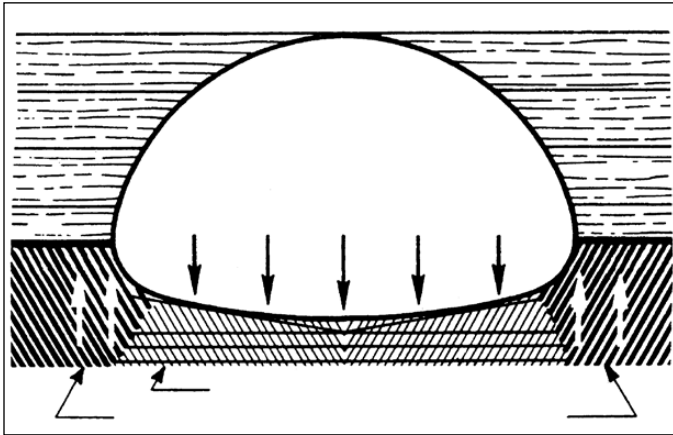

Recommended backfilling practice for larger pipe-arch, using a vee-shaped bed.



Example of backfilling for a larger pipe-arch installation.

Backfill Placement for Multi-Barrel Pipe Installation

Multi-barrel culvert installations need special attention during the backfilling process. It is important to keep the elevation of backfill between pipes evenly. As a rule of thumb, do not allow for backfill to exceed the elevation of one side of pipe to the other by more than 24". The drawings below show how proper sequencing of backfill should proceed to prevent pipe racking or pipe deflection.

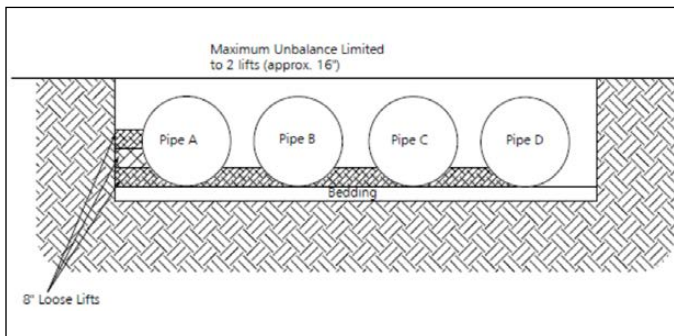

Detail for Maximum Unbalanced Limit

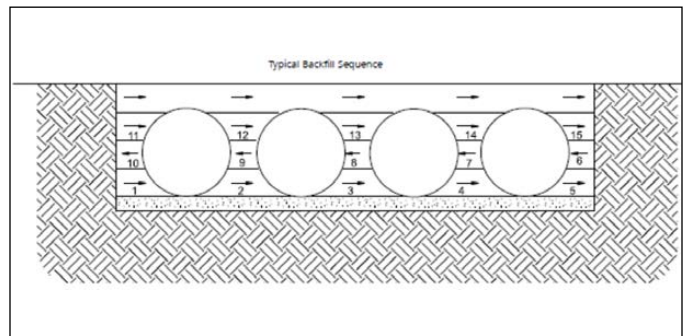

Detail for Typical Backfill Sequence



Examples of Multi-Barrel CMP Culverts



Final Cover Placement and Construction Loading

The minimum cover specified for a project normally assumes H-20 highway live loading. Backfill must be placed and fully compacted to the minimum cover level over the structure before the pipe is subjected to design loads. The minimum cover for AASHTO H-20 Live Loading per design section 12, is span of the pipe divided by eight plus asphalt pavement.

Construction loads often exceed design highway loading. During construction, keep heavy construction equipment that exceeds legal highway loads off the pipe. Light construction equipment on tracks such as a D-3 dozer (or lighter weight) may cross over the pipe when a minimum of 12" of compacted backfill is over pipe. Since construction equipment varies from job to job, it is best to address equipment specific minimum cover requirements with your local Contech Sales Engineer during your pre-construction meeting.

Minimum Height of Cover Requirements for Tracked Equipment HEL-COR® Corrugated Steel Pipe ¹					
Diameter (inches)	Minimum Cover (Ft)	Track Width (inches) Maximum Track Pressure at Surface (psi)			
		12	18	24	30
12 – 42	1.0	29	22	18	17
	1.5	58	41	34	30
	2.0	95	65	51	44
	2.5	138	91	70	59
	3.0	189	120	91	75
	4.0	321	195	143	115
48 – 66	1.0	10.6	8.0	6.9	6.2
	1.5	24	17	14.0	12.2
	2.0	39	26	21	18
	2.5	56	37	28	24
	3.0	77	49	37	30
	4.0	132	80	59	47
72 – 96	1.0	3.2	2.5	2.1	1.9
	1.5	8.8	6.2	5.0	4.4
	2.0	16	11.1	8.8	7.5
	2.5	24	15.0	12.0	10.1
	3.0	32	20	15	12.9
	4.0	56	34	25	20
102 – 120	1.0	2.8	2.1	1.7	1.6
	1.5	6.9	4.9	3.9	3.4
	2.0	14.8	10.1	8.0	6.7
	2.5	21	14.2	10.9	9.1
	3.0	29	18	14.1	11.6
	4.0	51	31	22	18
126 – 144	1.0	2.8	2.1	1.7	1.5
	1.5	6.0	4.3	3.5	3.0
	2.0	12.0	8.0	6.4	5.4
	2.5	21	14.0	10.6	8.9
	3.0	29	18	13.9	11.4
	4.0	50	30	22	18

¹ The values in this table represent the maximum ground pressure permitted when performing reasonable work over the pipes, using the manufacture's published equipment specifications. (Ground pressure for track equipment is the vehicle operating weight divided by the total ground contact area for both tracks.) This table is to be used as a guide. Talk to your Contech representative if you have questions about the equipment you plan on operating over the pipes. Care should be taken to maintain adequate cover depth during construction activities.



Examples of light, tracked, construction equipment used to place final cover over the pipe system.



Examples of heavy construction equipment that may require additional minimal cover. Contech can help evaluate minimum cover for the installation contractor for all the equipment on the site.

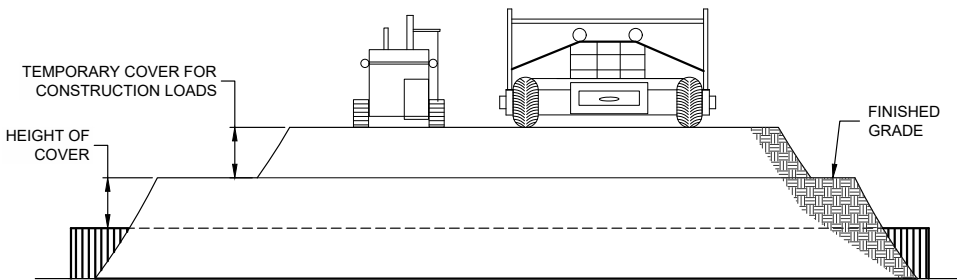

Minimum Height of Cover Requirements for Rubber-Tired Equipment Over HEL-COR® CSP

PIPE SPAN, INCHES	AXLE LOADS (kips)			
	18-50	50-75	75-110	110-150
	MINIMUM COVER (FT)			
12-42	2.0	2.5	3.0	3.0
48-72	3.0	3.0	3.5	4.0
78-120	3.0	3.5	4.0	4.0
126-144	3.5	4.0	4.5	4.5

FOR TEMPORARY CONSTRUCTION VEHICLE LOADS, AN EXTRA AMOUNT OF COMPACTED COVER MAY BE REQUIRED OVER THE TOP OF THE PIPE. THE HEIGHT-OF-COVER SHALL MEET THE MINIMUM REQUIREMENTS SHOWN IN THE TABLE BELOW. THE USE OF HEAVY CONSTRUCTION EQUIPMENT NECESSITATES GREATER PROTECTION FOR THE PIPE THAN FINISHED GRADE COVER MINIMUMS FOR NORMAL HIGHWAY TRAFFIC.

CMP Manhole Risers

CMP manhole risers allow easy access for future maintenance of the system. If the system is installed under a parking lot or road way subject to live loads, care must be taken to ensure loads are not applied directly to the riser structure. A pre-cast or cast-in-place slab should be installed above the riser. The manhole lid and frame should not rest directly on the CMP riser.

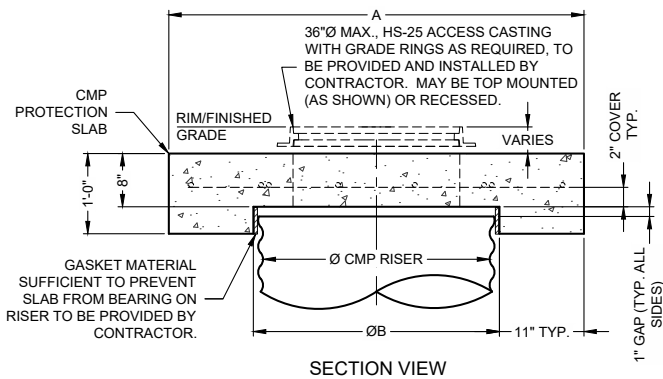

Reinforcing Table				
Ø CMP Riser	A	ØB	Reinforcing	Bearing Pressure** (psf)
24	4'Ø	26"	#5 @ 10" OCEW	2,540
	4' x 4'		#5 @ 10" OCEW	1,900
30"	4'-6"Ø	32"	#5 @ 10" OCEW	2,260
	4'-6" x 4'-6"		#5 @ 9" OCEW	1,670
36"	5'Ø	38"	#5 @ 9" OCEW	2,060
	5' x 5'		#5 @ 8" OCEW	1,500
42"	5'-6"Ø	44"	#5 @ 8" OCEW	1,490
	5'-6" x 5'-6"		#5 @ 8" OCEW	1,370
48"	6'Ø	50"	#5 @ 7" OCEW	1,210
	6' x 6'		#5 @ 7" OCEW	1,270

** Assumed soil bearing capacity.

Precast Option for Manhole Riser Caps

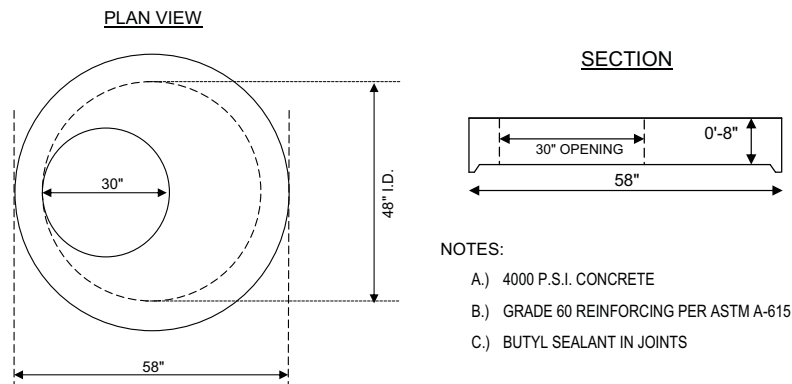

- NOTES:
- A) 4000 P.S.I. CONCRETE
 - B) GRADE 60 REINFORCING PER ASTM A-615
 - C) BUTYL SEALANT IN JOINTS

Precast Cap Details

- Heavy Duty 4,000 psi concrete
- Standard HS25 Loading
- Available for risers up to 72-inch
- Precast Cap – ASTM A615, Grade 60
- Frame & Grate/Cover – ASTM A48

Pipe End Treatment

Corrugated metal pipe end treatments can consist of squared end pipe with rip rap, metal end sections, concrete headwalls, metal headwalls, skewed ends, and beveled ends. For large diameter CMP culverts, beveled ends are popular for hydraulic improvement. Beveled cut ends can be cost-effective for large diameter end treatments.



Step bevel has both a bottom and top step with 2:1 slope..

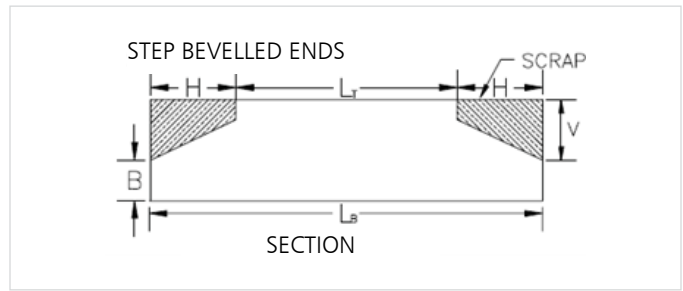

Partial bevel has only a bottom step with 2:1 slope.

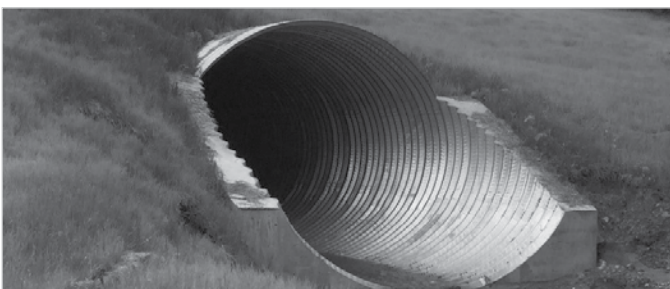
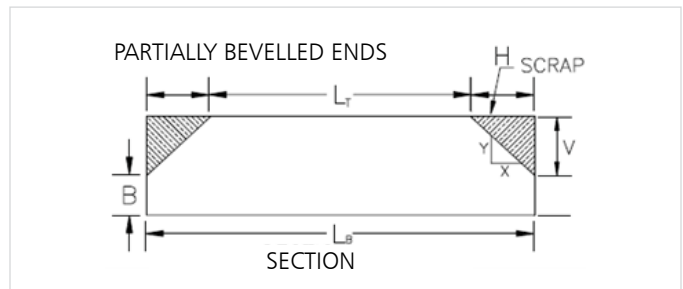

Concrete slope collars and cut off wall may be required on the bevel depending on size of the pipe, skew angle, and length of the bevel.

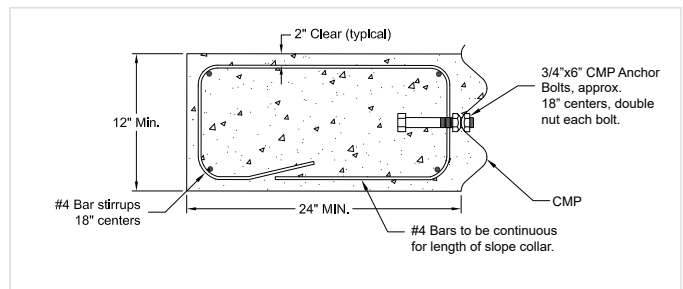

Additional Considerations

Because most systems are constructed below-grade, rainfall can rapidly fill the excavation; potentially causing floatation and movement of the previously placed pipes. To help mitigate potential problems, it is best to start the installation at the downstream end with the outlet already constructed to allow a route for the water to escape. Temporary diversion measures may be required for high flows due to the restricted nature of the outlet pipe.

Skewed Ends to Embankment

Corrugated metal pipe utilized for roadway crossings is many times skewed to the roadway embankment. This may lead to unbalanced soil loading conditions. It is important to properly balance (warp) embankment fill for both single and multiple barrel pipe installations. Additional embankment fill may need to be imported to balance the load over each side of the pipe system. Refer to ASTM A798 for additional information.

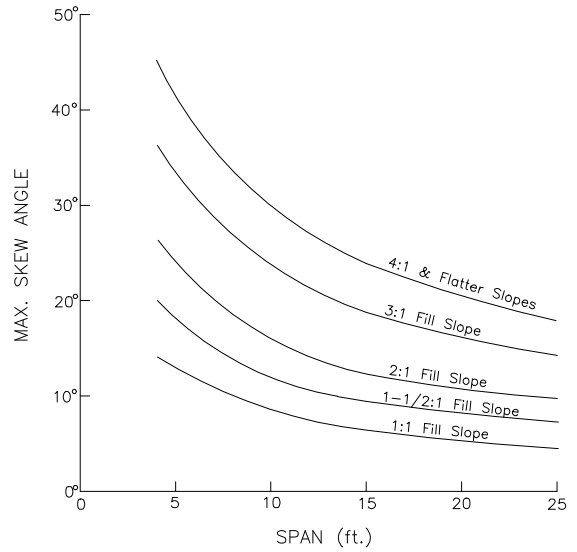
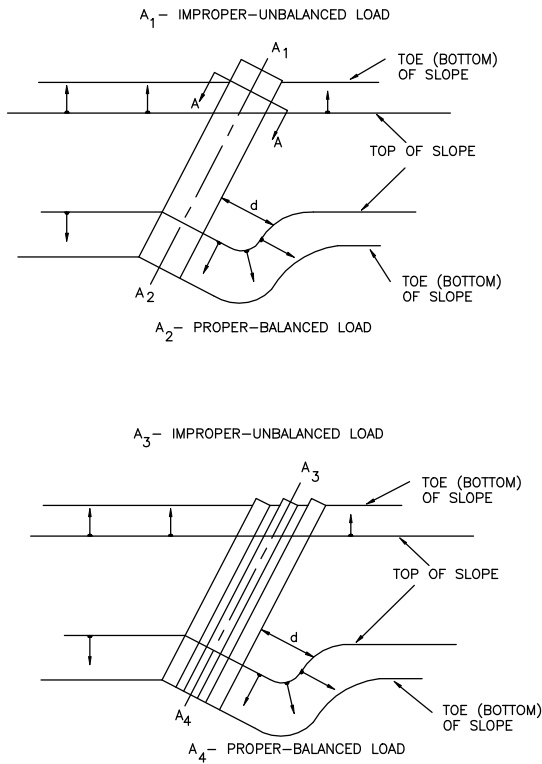

Industry References

For additional information, please reference the following sources:

- ASTM A798, Standard Practice for Installing Factory-Made Corrugated Steel Pipe for Sewers and Other Applications
- AASHTO Section 26, Standard Specifications for Highway Bridges-Division II, Section 26 LRF Bridge Construction
- AREMA Manual for Railway Engineering, Section 4.12
- National Corrugated Steel Pipe Association, Installation Manual for Corrugated Steel Pipe and Structural Plate





CMP Preconstruction Checklist

Contech Field Contact and Phone: _____

Contech Plant Contact and Phone: _____

Contractor Contact and Phone: _____

Project Name: _____

Site Address: _____

Pre-con Attendees: _____

Topics to Review:

- Truck access and pipe storage availability/expectation
- Pipe unloading and handling safety, equipment and procedures
- System layout and shop drawing review
- Shipping schedule and installation sequence
- Joint configuration and assembly
- Connection with unlike storm sewer materials
- Backfill material selection and placement strategy
- Backfill sequence, lift thickness and balanced loading
- Compaction requirement (90%) and equipment
- Additional cover requirements for heavy construction loads
- CMP riser concrete cap installation

Notes: _____

NOTHING IN THIS CATALOG SHOULD BE CONSTRUED AS A WARRANTY. APPLICATIONS SUGGESTED HEREIN ARE DESCRIBED ONLY TO HELP READERS MAKE THEIR OWN EVALUATIONS AND DECISIONS, AND ARE NEITHER GUARANTEES NOR WARRANTIES OF SUITABILITY FOR ANY APPLICATION. CONTECH MAKES NO WARRANTY WHATSOEVER, EXPRESS OR IMPLIED, RELATED TO THE APPLICATIONS, MATERIALS, COATINGS, OR PRODUCTS DISCUSSED HEREIN. ALL IMPLIED WARRANTIES OF MERCHANTABILITY AND ALL IMPLIED WARRANTIES OF FITNESS FOR ANY PARTICULAR PURPOSE ARE DISCLAIMED BY CONTECH. SEE CONTECH'S CONDITIONS OF SALE (AVAILABLE AT WWW.CONTECHES.COM/COS) FOR MORE INFORMATION.