

The Rapterra system will be (or has been) delivered to you with protection in place to resist intrusion of construction related sediment which can contaminate the biofiltration media and result in inadequate system performance. These protection devices are intended as a best practice and cannot fully prevent contamination. It is the purchaser's responsibility to provide adequate measures to prevent construction related runoff from entering the Rapterra system.

Included with your purchase is Activation of the Rapterra system by the manufacturer as well as a 1-year warranty from delivery of the system and a Final Site Assessment (assessment of unit condition, mulch replacement, debris removal, and pruning of vegetation if applicable) scheduled between 6 months and 1 year after Activation, upon request.

Activation of the Rapterra system is a procedure completed by the manufacturer to place the system into working condition. This involves the following items:

- Removal of construction runoff protection devices
- Planting of the system's vegetation (provided by the purchaser where specified and/or required)
- Placement of pretreatment mulch layer using mulch acceptable for use in Rapterra systems.
- Placement of scour netting over the mulch layer.

Activation MUST be provided by the manufacturer to ensure proper site conditions are met for Activation, proper installation of the vegetation (where applicable), and use of pretreatment mulch acceptable for use in Rapterra systems. The purchaser should request Activation from Contech after the site is stabilized, but prior to turning over the site to the owner. Please allow 1-2 weeks to schedule Activation.

The purchaser must ensure that the site is acceptable for Rapterra Activation. A checklist (included as page 3 of this document must be completed and submitted to the Contech Activation Coordinator. The minimum 4 requirements for Rapterra Activation are as follows:

1. If vegetation is specified and/or required, the purchaser must have sourced vegetation meeting the requirements outlined in "Plant Selection for Rapterra Systems" starting on page 4 of this document.



* UNPREPARED SITE FEE NOTE: A charge of \$1500.00 will be invoiced for each activation visit requested by customer where Contech determines that the site does not meet the conditions required for Activation AND/OR acceptable plants (when specified and/or required) are not provided by the contractor. ONLY Contech authorized representatives can perform Activation of Rapterra systems; unauthorized activations will void the system warranty and waive manufacturer supplied activation and final inspection.

2. The site landscaping must be fully stabilized, i.e. full landscaping installed and some grass cover (not just straw and seed) is required to reduce sediment transport. Construction debris and materials should be removed from surrounding area.



3. Final paving must be completed. Final paving ensures that paving materials will not enter and contaminate the Rapterra system during the paving process, and that the plant will receive runoff from the drainage area, assisting with plant survival for the Rapterra system.



4. Where curb inlets are included as part of the Rapterra system, Rapterra throat opening should be at least 4" clear in order to ensure adequate capacity for inflow and debris.

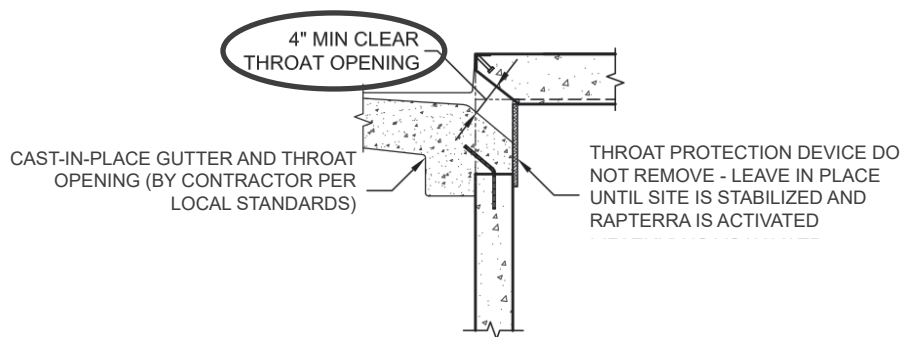

* UNPREPARED SITE FEE NOTE: A charge of \$1500.00 will be invoiced for each activation visit requested by customer where Contech determines that the site does not meet the conditions required for Activation AND/OR acceptable plants (when specified and/or required) are not provided by the contractor. ONLY Contech authorized representatives can perform Activation of Rapterra systems; unauthorized activations will void the system warranty and waive manufacturer supplied activation and final inspection.

Rapterra™ Vault Activation Checklist



Project Name: _____ Company: _____

Site Contact Name: _____ Site Contact Phone/Email: _____

Site Owner/End User Name: _____ Site Owner/End User Phone/Email: _____

Preferred Activation Date: _____ (provide 2 weeks minimum from date this form is submitted)

Site Designation	Top Opening Type	Final Pavement Complete	Landscaping Complete / Grass Emerging	Construction materials / Piles / Debris Removed	Throat Opening Measures 4" Min. Height (where applicable)	Vegetation Sourced by Contractor (where applicable)
	<input type="checkbox"/> Tree Grate <input type="checkbox"/> Full Grate (No tree opening) <input type="checkbox"/> Bioscape Vault (Open Planter)	<input type="checkbox"/> Verified	<input type="checkbox"/> Verified	<input type="checkbox"/> Verified	<input type="checkbox"/> Verified	<input type="checkbox"/> Species on FT Plant List <input type="checkbox"/> Container Grown (15 gal. max) <input type="checkbox"/> 4' Tall Min. (Tree grate units only) _____ Qty provided
	<input type="checkbox"/> Tree Grate <input type="checkbox"/> Full Grate (No tree opening) <input type="checkbox"/> Bioscape Vault (Open Planter)	<input type="checkbox"/> Verified	<input type="checkbox"/> Verified	<input type="checkbox"/> Verified	<input type="checkbox"/> Verified	<input type="checkbox"/> Species on FT Plant List <input type="checkbox"/> Container Grown (15 gal. max) <input type="checkbox"/> 4' Tall Min. (Tree grate units only) _____ Qty provided
	<input type="checkbox"/> Tree Grate <input type="checkbox"/> Full Grate (No tree opening) <input type="checkbox"/> Bioscape Vault (Open Planter)	<input type="checkbox"/> Verified	<input type="checkbox"/> Verified	<input type="checkbox"/> Verified	<input type="checkbox"/> Verified	<input type="checkbox"/> Species on FT Plant List <input type="checkbox"/> Container Grown (15 gal. max) <input type="checkbox"/> 4' Tall Min. (Tree grate units only) _____ Qty provided
	<input type="checkbox"/> Tree Grate <input type="checkbox"/> Full Grate (No tree opening) <input type="checkbox"/> Bioscape Vault (Open Planter)	<input type="checkbox"/> Verified	<input type="checkbox"/> Verified	<input type="checkbox"/> Verified	<input type="checkbox"/> Verified	<input type="checkbox"/> Species on FT Plant List <input type="checkbox"/> Container Grown (15 gal. max) <input type="checkbox"/> 4' Tall Min. (Tree grate units only) _____ Qty provided

Attach additional sheets as necessary.

NOTE: A charge of \$1500.00 will be invoiced for each activation visit requested by customer where Contech determines that the site does not meet the conditions required for activation AND/OR acceptable plants are not provided by the contractor. ONLY Contech authorized representatives can perform activation of Rapterra systems; unauthorized activations will void the system warranty and waive manufacturer supplied activation and final inspection.

Signature

Date

* UNPREPARED SITE FEE NOTE: A charge of \$1500.00 will be invoiced for each activation visit requested by customer where Contech determines that the site does not meet the conditions required for Activation AND/OR acceptable plants (when specified and/or required) are not provided by the contractor. ONLY Contech authorized representatives can perform Activation of Rapterra systems; unauthorized activations will void the system warranty and waive manufacturer supplied activation and final inspection.

Planting Selection for Rapterra™ Vault Systems Specifying and/or Requiring Plants

Vegetation is recommended in Rapterra for proper long-term performance. As indicated in the Activation Package, the Contractor is responsible for sourcing the proper vegetation prior to Activation. Contech or a Contech representative will install the vegetation during the Activation process.

Contractors should identify the Top Opening style for each Rapterra requiring Activation on the Activation Checklist. Contech offers three types, which are detailed on page 5 of this document:

- Vault with Tree Grate
- Vault with Full Grate
- Bioscape / Open Planter

Contractors must ensure the vegetation meets the following 4 requirements:

1. Select plant(s) as specified in the engineering plans and specifications AND that are listed on Contech's Configuration Specific Plant Lists**.
2. All plants MUST be container-grown in nursery containers no larger than 15 gallons. Crated and/or Ball/Burlap plants are NOT permitted.
3. For Vaults with Tree Grates, plant height must be 4' Minimum, from soil surface to top of plant.
4. Provide plant quantities per the following guidance:
 - Vault with Tree Grate – 1 per Tree Grate
 - Vault with Full Grate – 4-5 Small or Extra Small Grasses per Full Grate
 - Bioscape – Quantities should be selected based on plant palette options found starting on page 6 of this document.



If Contech or Contech's representative shows up for Activation and any of the 4 requirements above are not met, Activation cannot be performed and the Contractor will be billed a \$1,500 Unprepared Site fee*.

Some additional vegetation recommendations for the best possible Activation and Installation are as follows:

- Select plant(s) with full root development but not to the point where root bound.
- For Rapterra systems with a Tree Grate, select plants with taller trunks. Lower branches can be pruned away provided there are sufficient branches above the grate for tree or shrub development.
- For Rapterra systems with a Tree Grate, plant(s) should have a single trunk at installation.
- Plant species shall not have a mature height greater than 30 feet.

** In some cases, Contech may consider alternate plant species as approved by the Product Manager. Please list the plant name in the space below and submit this sheet to your Contech Activation Coordinator. If the plant species is approved, either the Product Manager or the Activation Coordinator will sign the form and return to you for inclusion with your Activation Checklist.

Requested Plant Species: _____ Approved: _____

Date: _____

* UNPREPARED SITE FEE NOTE: A charge of \$1500.00 will be invoiced for each activation visit requested by customer where Contech determines that the site does not meet the conditions required for Activation AND/OR acceptable plants (when specified and/or required) are not provided by the contractor. ONLY Contech authorized representatives can perform Activation of Rapterra systems; unauthorized activations will void the system warranty and waive manufacturer supplied activation and final inspection.

Rapterra™ Top Opening Examples

Rapterra™ Vault with Tree Grate

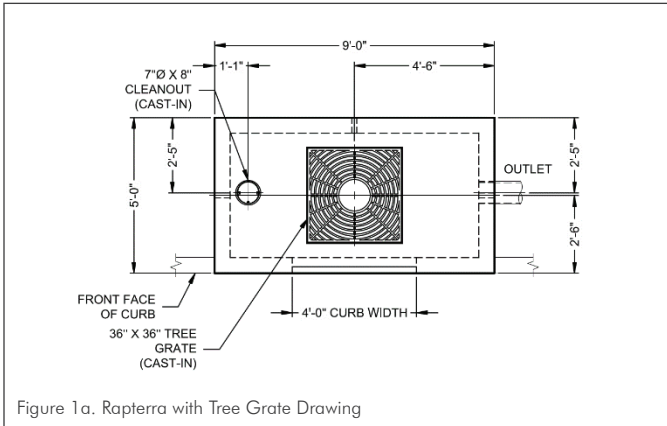

Rapterra™ Vault with Full Grate

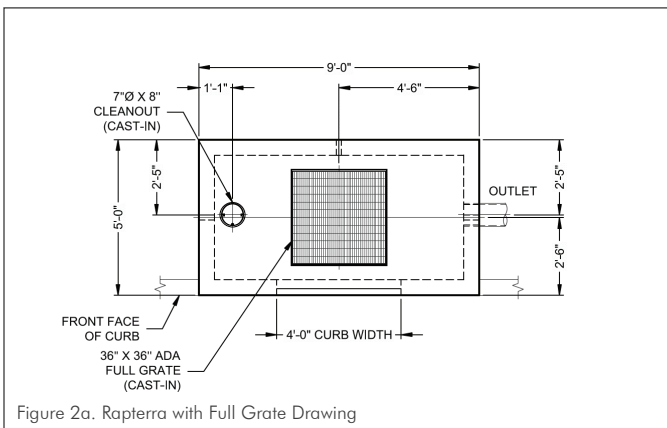

Rapterra™ Bioscape Vault

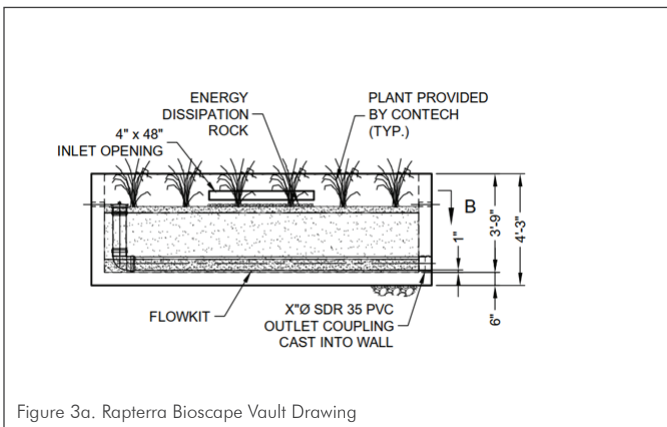

* UNPREPARED SITE FEE NOTE: A charge of \$1500.00 will be invoiced for each activation visit requested by customer where Contech determines that the site does not meet the conditions required for Activation AND/OR acceptable plants (when specified and/or required) are not provided by the contractor. ONLY Contech authorized representatives can perform Activation of Rapterra systems; unauthorized activations will void the system warranty and waive manufacturer supplied activation and final inspection.

Rapterra™ Bioscape Vault Plant Palettes

KEY: (refer to plant lists for species sizing)

A. EXTRA SMALL GRASS

- Up to 2' mature spread
- 1-2 gallon typical (1 gal. minimum)

B. SMALL GRASS/SHRUB

- 2'-4' mature spread
- 1-7 gallon typical

C. MEDIUM SHRUB

- 4'-6' mature spread
- 1-7 gallon typical

D. LARGE SHRUB OR EXTRA LARGE SHRUB OR TREE

- 6' mature spread and greater, 30' max. mature height
- Up to 15 gallon maximum

NOTE: For larger vaults and in-ground Rapterra Bioscape systems, palettes can be scaled (i.e. Qty 6 of the 22x8 Palette can be used for a 1056 sf Rapterra Bioscape).

MIX & MATCH SUBSTITUTION OPTIONS:

- 1 Large Shrub or Extra Large Shrub or Tree
 - 2 Medium Shrubs
 - 4 Small Grass/SHrubs
 - 12 Extra Small Grasses

- 1 Medium Shrub
 - 2 Small Grass/SHrubs
 - 6 Extra Small Grasses

- 1 Small Grass/SHrub
 - 3 Extra Small Grasses

4x4 Media Bay



4x6/6x4 Media Bay



4x8/8x4 & 4.5x7.83/7.83x4.5 Media Bay

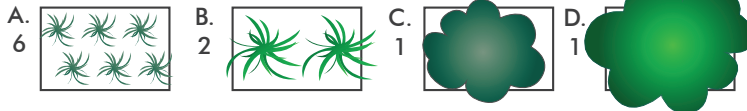

6x6 Media Bay

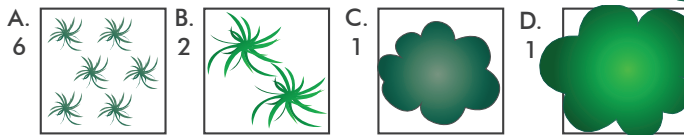

6x8/8x6 Media Bay

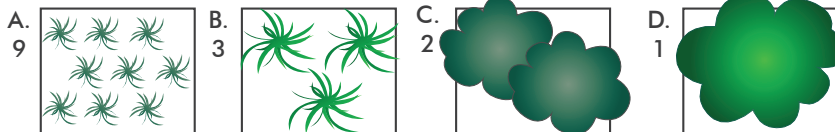

6x10/10x6 & 8x8 Media Bay

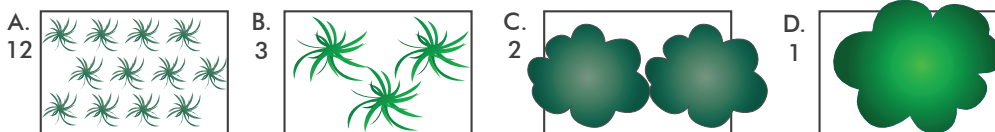

6x12/12x6 Media Bay

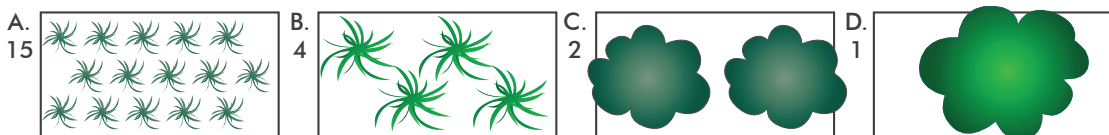

7x13/13x7/12x8 & 14x8 Media Bay

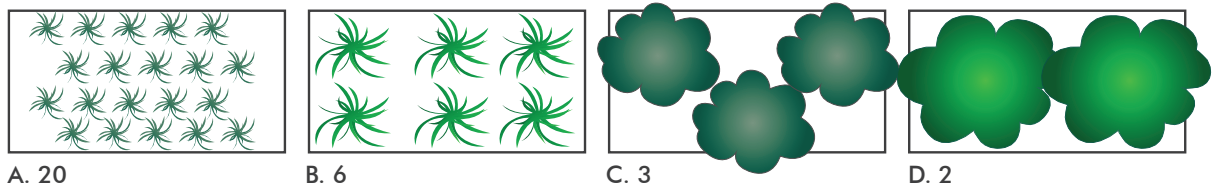

* UNPREPARED SITE FEE NOTE: A charge of \$1500.00 will be invoiced for each activation visit requested by customer where Contech determines that the site does not meet the conditions required for Activation AND/OR acceptable plants (when specified and/or required) are not provided by the contractor. ONLY Contech authorized representatives can perform Activation of Rapterra systems; unauthorized activations will void the system warranty and waive manufacturer supplied activation and final inspection.

16x8 & 15x9
Media Bay

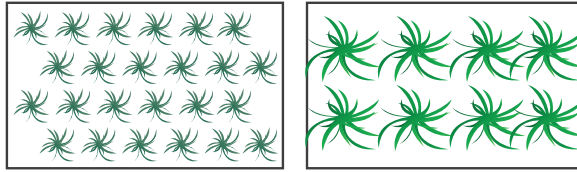

A. 24

B. 8

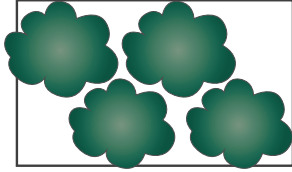

C. 4

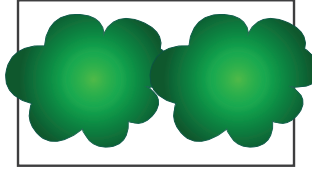

D. 2

18x8 Media Bay

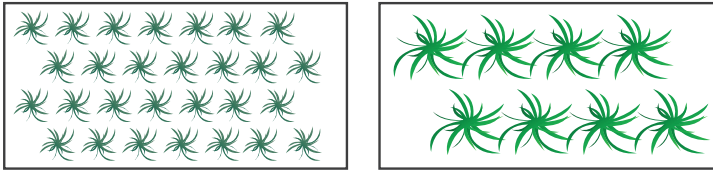

A. 28

B. 8

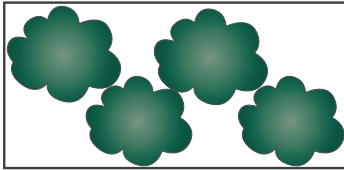

C. 4

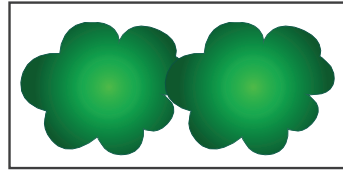

D. 2

20x8 Media Bay

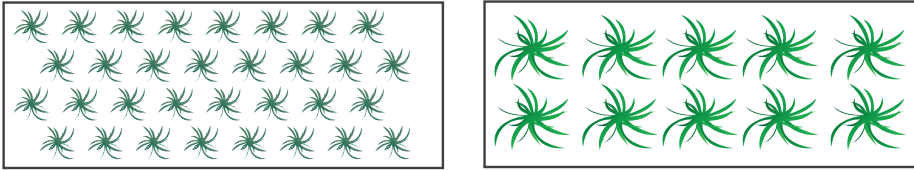

A. 32

B. 10



C. 5

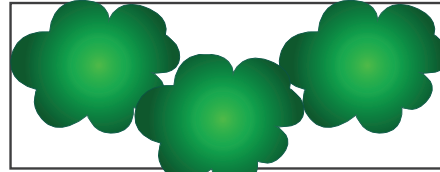

D. 3

22x8 Media Bay

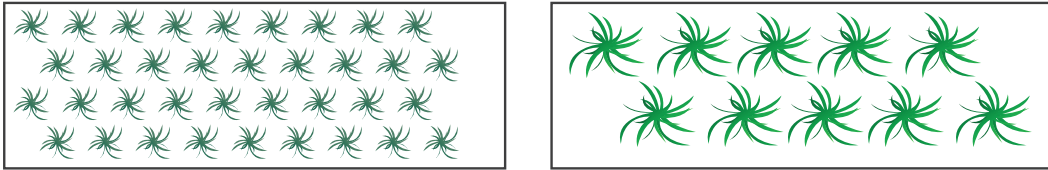

A. 36

B. 10

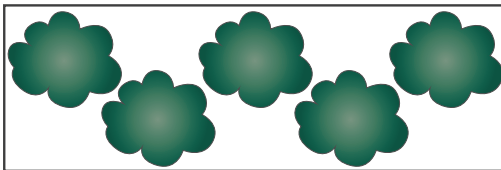

C. 5

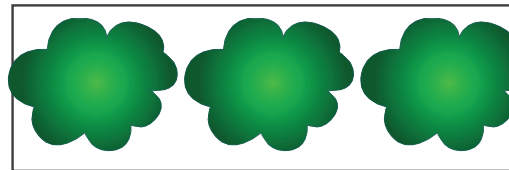

D. 3

* UNPREPARED SITE FEE NOTE: A charge of \$1500.00 will be invoiced for each activation visit requested by customer where Contech determines that the site does not meet the conditions required for Activation AND/OR acceptable plants (when specified and/or required) are not provided by the contractor. ONLY Contech authorized representatives can perform Activation of Rapterra systems; unauthorized activations will void the system warranty and waive manufacturer supplied activation and final inspection.

