

DuroMaxx[®] SRPE Detention and Infiltration Installation Guide



DuroMaxx® Detention and Infiltration Installation Guide

DuroMaxx Steel Reinforced Polyethylene Pipe (SRPE) is a flexible pipe. Proper installation of a flexible pipe underground detention system will ensure long-term performance. The configuration of the system often requires special construction practices that differ from conventional flexible pipe construction. Contech strongly suggest scheduling a pre-construction meeting with your local Sales Engineer to determine if additional measures, not covered in this guide, are appropriate for your site. All OSHA and local safety guidelines should be observed during the construction of the system and site.

Preconstruction Meeting

It is a best practice to have a pre-construction meeting with the installation contractor and Contech personnel. Included at the end of this guide is a preconstruction checklist to review prior to installation.

Proper Pipe Unloading, Handling and Placement

The pipe should be unloaded with a fork lift, excavator, crane or other piece of construction equipment. The pipe should never be dropped or pushed off the flatbed trailer. For any piece 20' and longer, nylon slings should be used to lift the pipe off the truck into place.

Normally the header row pipe section is placed on the downstream end first. For detention systems with a single header row on one end and pipe with bulkheads on the other end; it is a best practice to start pipe placement on the header row end. If DuroMaxx with a bell and spigot is used, proper storage practices should be used to prevent any damage to the bell end of the pipe. The gaskets shall be kept clean and free from any dirt or stone particles.



Lifting DuroMaxx off the flatbed with a frontend loader with forks.



Lifting DuroMaxx into place with an excavator using nylon slings. When longer pieces are used, multiple nylon slings spaced 1/3 of the pipe apart should be used.

Foundation and Pipe Bedding

Construct a foundation that can support the design loading applied by the pipe and adjacent backfill weight as well as maintain its integrity during construction. If soft or unsuitable soils are encountered, remove the poor soils to a suitable depth and then replace with a competent granular material to the appropriate elevation. The granular material gradation should not allow the migration of fines, which can cause settlement of the detention system or pavement above. If the structural fill material is not compatible with the underlying soils a geotextile fabric should be used as a separator. Refer to ASTM D2321, for suitable material and proper placement of flexible pipe.

Grade the foundation subgrade to a uniform or slightly sloping grade. If the subgrade is clay or relatively non-porous and the construction sequence will last for an extended period of time, it is best to slope the grade to one end of the system. This will allow excess water to drain quickly, preventing saturation of the subgrade.

A 4" – 6" thick, well-graded granular material is preferred pipe bedding. If the existing foundation is made up of a course sand or other suitable granular material, imported bedding material will not be required.



Site conditions may require 4" – 6" of imported granular material as pipe bedding.

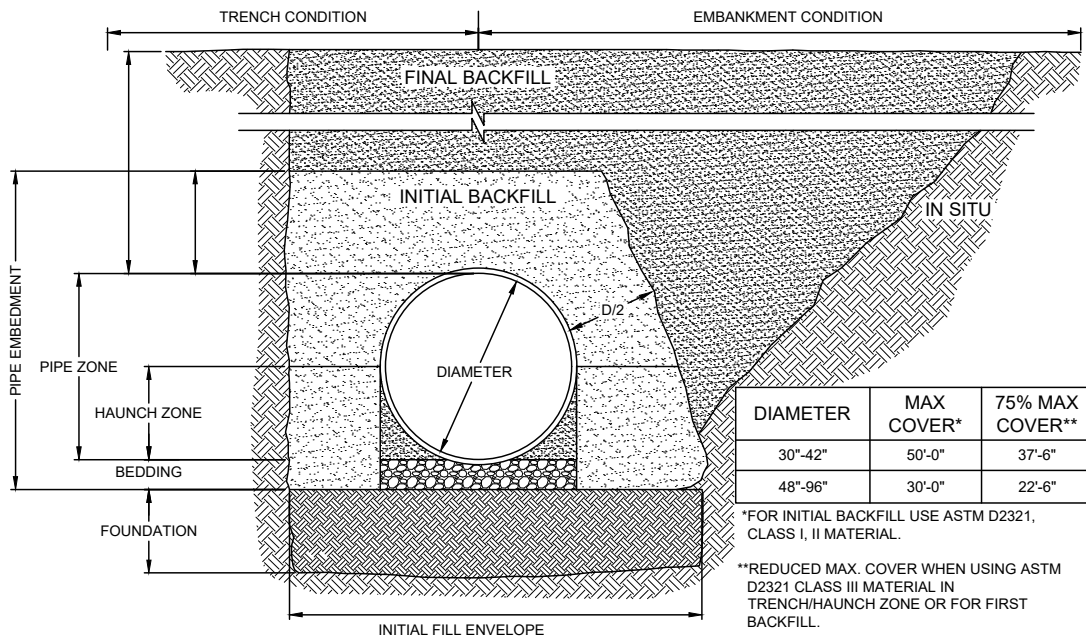

High Performance (Bell & Spigot) Joints

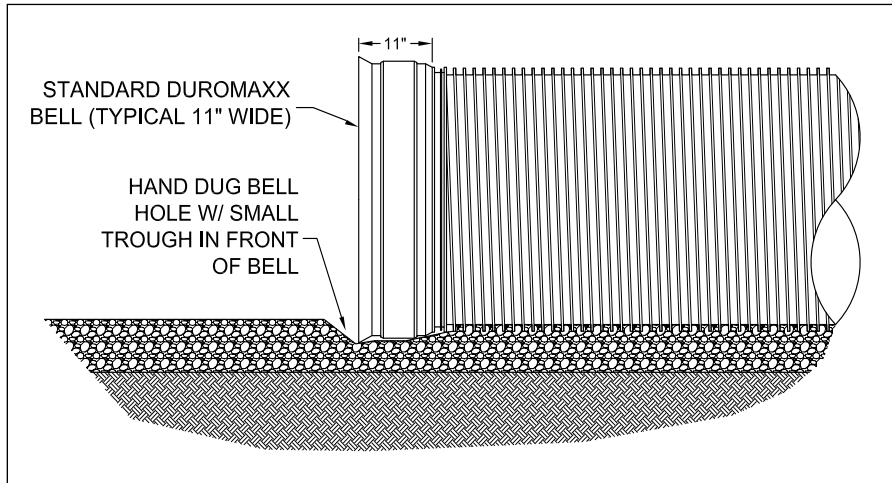
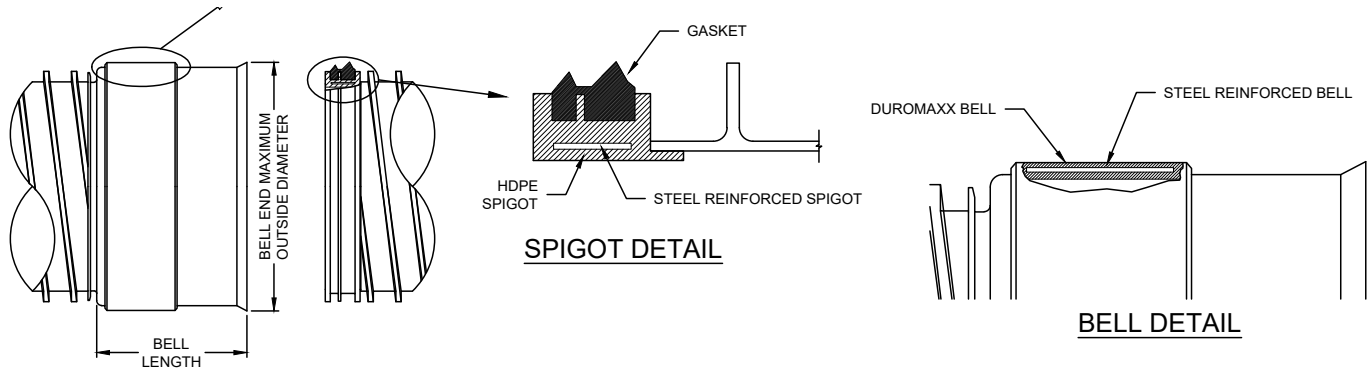

A "bell hole" needs to be dug under the bell end of the pipe to accommodate the diameter difference.



A best practice for bell and spigot joints is to lay a steel plate under the bell to help "home" the next pipe.

Welded Coupler Joints

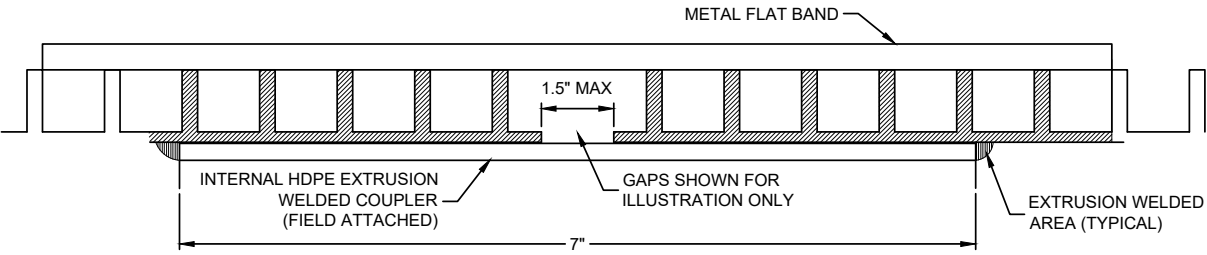

Installing a flat gasket and band around DuroMaxx plain end pipe.



Tightening bolts on a flat band.



Internally welding pipe joints. The pipe needs to be backfilled prior to the joints being welded together. The pipe should be clean and dry. The gap between the two pipes should be limited to 1.5" maximum. The maximum pipe misalignment is 1/4". Pipe joints outside recommendations could result in higher joint welding costs.

In-Situ Trench Wall

If excavation is required, the trench wall needs to be capable of supporting the load that the pipe sheds as the system is loaded. If soils are not capable of supporting these loads, the pipe can deflect. Perform a simple soil pressure check using the applied loads to determine the limits of excavation beyond the spring line of the outer most pipes. Poor in-situ trench wall soils may require a wider structural trench.

In most cases the requirements for a safe work environment and proper backfill placement and compaction take care of the concern.

Backfill Material

DuroMaxx® SRPE is a flexible pipe that is designed per AASHTO Design Section 12. All buried flexible pipes are dependent on a quality backfill material for structural support. The best backfill material is an angular, well-graded, granular fill meeting the requirements of AASHTO M 145, Classes A-1-a, A-1-b, A-3, A-2-4, A-2-5, or ASTM D2321, Classes I, II or III. AASHTO M 145, Class A-1-a (ASTM D2321, Class I) backfill is recommended for 108" diameter and larger. The maximum aggregate particle size shall not exceed 2.5" in diameter.

Backfill using controlled low-strength material (CLSM, "flash fill", or "flowable fill") is acceptable when the spacing between the pipes will not allow for placement and adequate compaction of the backfill.

EXAMPLES OF ACCEPTABLE BACKFILL MATERIAL



Course Sand



Crushed Limestone

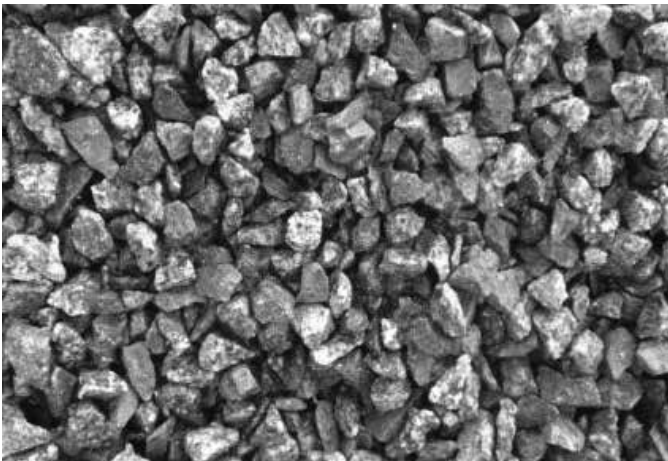

Crushed Granite



Crushed River Gravel

Backfill Placement

DuroMaxx SRPE is made from a high quality polyethylene resin. Polyethylene does have a high coefficient of thermal expansion. It is recommended that each pipe be completely backfilled the same day it is placed to minimize expansion and contraction due to large potential temperature swings of day and night. If backfilling the same day is not feasible, backfill the pipe when the temperature is similar to when the pipe joints were first installed.

The backfill shall be placed in 8" +/- loose lifts and compact to 90% AASHTO T99 standard proctor density. Material shall be worked into the pipe haunches by means of shovel-slicing, rodding, vibratory packer, or other effective methods. If AASHTO T99 procedures are determined infeasible by the geotechnical engineer of record, compaction is considered adequate when no further yielding of the material is observed under the compactor, or under foot, and the geotechnical engineer of record (or representative thereof) is satisfied with the level of compaction.

For large systems, conveyor systems, or backhoes with long reaches may be used to place backfill. Once minimum cover for the construction loading across the entire width of the system is reached, advance the equipment to the end of the recently placed fill, and begin the sequence again until the system is completely backfilled. This type of construction sequence provides room for stockpiled backfill directly behind the backhoe, as well as the movement of construction traffic.

It is important to keep the elevation of backfill between pipes and between the pipe and side embankment evenly. As a rule of thumb, do not allow for backfill to exceed the elevation of one side of pipe to the other and pipe to side embankment by more than two (2) compacted lifts.

Material stockpiles on top of the backfilled detention system should be limited to 8' +/- high and must provide balanced loading across all barrels. To determine the proper minimum cover over the pipes to allow the movement of construction equipment, contact your local Contech Sales Engineer.

If CLSM or "flowable fill" is used as backfill, pipe flotation needs to be prevented. Typically, small lifts are placed between the pipes and then allowed to set-up prior to the placement of the next lift. The allowable thickness of the CLSM lift is a function of a proper balance between the uplift force of the CLSM, the opposing weight of the pipe, and the effect of other restraining measures. Your local Sales Engineer can help determine an appropriate lift thickness.

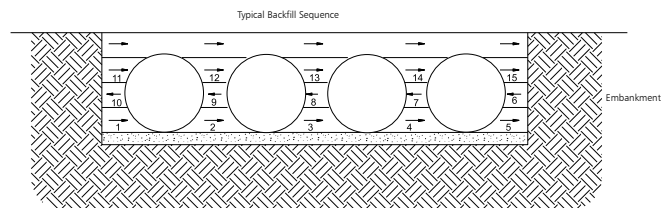
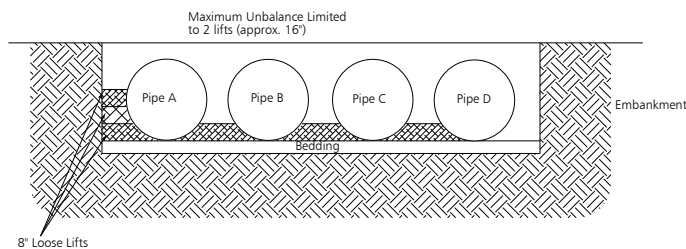

Placing backfill with a stone conveyor.



Compaction with vibratory equipment.

Final Cover Placement and Construction Loading

The minimum cover specified for a project normally assumes H-20 highway live loading. Backfill must be placed and fully compacted to the minimum cover level over the structure before the pipe is subjected to design loads. Construction loads often exceed design highway loading. During construction, keep heavy construction equipment that exceeds legal highway loads off the pipe.

Values in the table below represent the maximum ground pressure permitted when performing reasonable work over the pipes, using the manufacturer's published equipment specifications. (Ground pressure for tracked equipment is the vehicle operating weight divided by the total ground contact area for both tracks). This table is to be used as a guide. Talk to your Contech representative if you have questions about the equipment you plan on operating over the pipes. Care should be taken to maintain adequate cover depth during construction activities.

Minimum Height of Cover Requirements for Tracked Loading DuroMaxx® SRPE					
Diameter	Minimum Cover (Ft)	Track Width (inches) Maximum Track Pressure at Surface (psi)			
		12	18	24	30
30	1.0	43	32	28	25
	1.5	86	61	50	44
	2.0	139	95	76	65
	2.5	204	134	104	87
	3.0	278	177	134	111
	4.0	469	286	209	168
36	1.0	35	26	22	20
	1.5	69	50	41	36
	2.0	113	78	61	53
	2.5	166	109	84	71
	3.0	226	144	109	90
	4.0	383	233	171	137
42	1.0	29	22	19	17
	1.5	58	41	34	30
	2.0	95	65	51	44
	2.5	139	91	71	59
	3.0	190	121	92	76
	4.0	322	196	143	115
48	1.0	18	14.0	12.0	10.8
	1.5	37	26	21	18
	2.0	60	41	32	27
	2.5	87	57	44	37
	3.0	119	76	58	47
	4.0	203	124	90	73
54	1.0	16	12.1	10.4	9.3
	1.5	31	23	18	16
	2.0	52	35	28	24
	2.5	76	50	38	32
	3.0	104	66	50	41
	4.0	176	107	78	63
60	1.0	14.8	11.1	9.5	8.5
	1.5	29	21	17	15
	2.0	48	32	25	22
	2.5	69	45	35	29
	3.0	95	60	45	37
	4.0	162	98	72	58

Minimum Height of Cover Requirements for Tracked Loading DuroMaxx® SRPE					
Diameter	Minimum Cover (Ft)	Track Width (inches) Maximum Track Pressure at Surface (psi)			
		12	18	24	30
66	1.0	12.5	9.5	8.1	7.3
	1.5	28	20	16	14.4
	2.0	45	31	24	21
	2.5	67	44	34	28
	3.0	91	58	43	36
	4.0	123	95	69	55
72	1.0	9.7	7.4	6.3	5.6
	1.5	23	16	13.8	12.1
	2.0	38	26	20	17
	2.5	56	37	28	23
	3.0	76	48	36	30
	4.0	131	80	58	47
84	1.0	7.4	5.6	4.7	4.3
	1.5	20	14.6	11.9	10.4
	2.0	33	22	18	15
	2.5	49	32	24	20
	3.0	66	42	32	26
	4.0	114	69	50	40
96	1.0	5.1	3.9	3.4	3.0
	1.5	14.8	10.3	8.4	7.3
	2.0	25	17	13.8	11.8
	2.5	37	24	18	15
	3.0	50	32	24	20
	4.0	88	53	39	31
108	1.0	3.7	2.9	2.4	2.2
	1.5	10.2	7.2	5.9	5.1
	2.0	20	13.8	10.9	9.3
	2.5	29	19	14.9	12.4
	3.0	40	25	19	15
	4.0	69	42	31	24
120	1.0	2.8	2.3	1.9	1.7
	1.5	7.4	5.3	4.4	4.1
	2.0	16	11.1	8.8	7.5
	2.5	24	15	12.0	10.1
	3.0	32	20	15	12.9
	4.0	56	34	25	20

- Tracked dozers don't exhibit the same variability in pressures under their tracks as other pieces of construction equipment. Therefore, the maximum track pressures shown above can be increased by a multiplier of 2.5 when applied to tracked dozers.
- The track widths shown above are for single tracks. If your equipment has different track widths, use the width that most closely corresponds to your equipment or extrapolate from the widths shown.



Examples of light, tracked, construction equipment used to place final cover over the pipe system.

Heavy Construction Loads

Minimum Height of Cover Requirements for Construction Loads. The Minimum Cover should be COMPACTED.

Diameter (inches)	Axle Load (Kips)			
	>32≤50	50≤75	75≤100	110≤150
30-42	2.0 ft	2.5 ft	3.0 ft	3.0 ft
48-72	3.0 ft	3.0 ft	3.5 ft	4.0 ft
84-96	3.0 ft	3.5 ft	4.0 ft	4.5 ft
102-120	3.5 ft	4.0 ft	4.5 ft	5.0 ft



Examples of heavy construction equipment that may require additional minimal cover.

DuroMaxx® SRPE Manhole Risers

DuroMaxx manhole risers allow easy access for future maintenance of the system. If the system is installed under a parking lot or road way subject to live loads, care must be taken to ensure loads are not applied directly to the riser structure. A pre-cast or cast-in-place slab should be installed above the riser. The manhole lid and frame should not rest directly on the DuroMaxx riser.



Reinforcing Table

Ø CMP Riser	A	ØB	Reinforcing	Bearing Pressure** (psf)
24	4'Ø 4' x 4'	26"	#5 @ 10" OCEW #5 @ 10" OCEW	2,540 1,900
30"	4'-6"Ø 4'-6" x 4'-6"	32"	#5 @ 10" OCEW #5 @ 9" OCEW	2,260 1,670
36"	5'Ø 5' x 5'	38"	#5 @ 9" OCEW #5 @ 8" OCEW	2,060 1,500
42"	5'-6"Ø 5'-6" x 5'-6"	44"	#5 @ 8" OCEW #5 @ 8" OCEW	1,490 1,370
48"	6'Ø 6' x 6'	50"	#5 @ 7" OCEW #5 @ 7" OCEW	1,210 1,270

** Assumed soil bearing capacity.

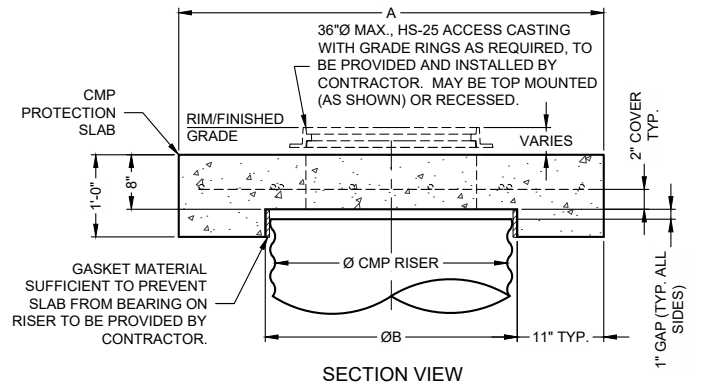

Precast option for manhole riser caps.

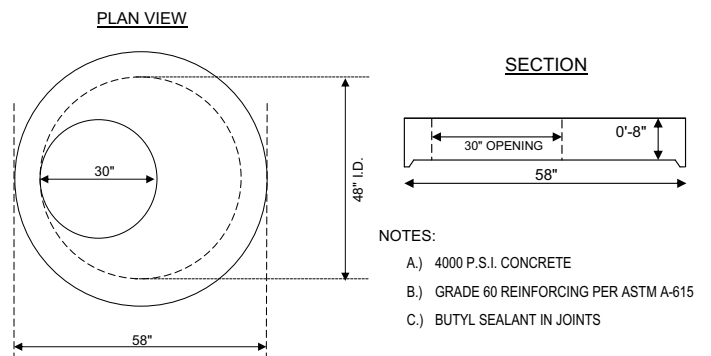

Additional Fittings Reinforcement

Some fittings (tees, risers, etc.) may require additional reinforcement. Additional reinforcement would include flowable fill or concrete fill around the mainline pipe in the area of the fitting.



Additional Considerations

Because most systems are constructed below-grade, rainfall can rapidly fill the excavation, potentially causing floatation and movement of the previously placed pipes. To help mitigate potential problems, it is best to start the installation at the downstream end with the outlet already constructed to allow a route for the water to escape. Temporary diversion measures may be required to handle high flows due to the restricted nature of the outlet pipe.

DuroMaxx Preconstruction Checklist

Contech Field Contact / Phone: _____

Contech Plant Contact / Phone: _____

Contractor Contact / Phone: _____

Project Name: _____

Site Address: _____

Pre-con Attendees: _____

Topics to Review:

- Expected delivery dates
- Starting station/location
- Drawing review
- Unloading and handling
 - Handling weights
 - Unloading and moving
 - Use nylon slings, approved unloading pole, or full length forks adequately spaced
 - Slings at 1/3 points of pipes length for pipes > 30"Ø
 - Forks need to be free of protrusions or spikes (typical protrusion to be mindful of is on the vertical back of the forks)
 - Storage
 - Store pipe on dunnage with bells and spigots raised off the ground
 - Do not set bells or spigots directly on top of dunnage
- Trench dimensions
- Bedding
 - 4" to 6" of relatively loose material on adequate foundation
 - If foundation is not adequate, it must be stabilized at the engineer's direction
- Bell and spigot assembly, if applicable
 - Dig a bell hole in the bedding to accommodate the larger diameter bell
 - Place a reusable skid plate under in front of the joint (remove after joint is made)
 - Ensure proper gasket placement (a visible white line in front of the gasket indicates improper seating)
 - Lube the bell and the spigot
 - Use of a restraint, which sits between the ribs, to restrain pipe movement during jointing can help
 - Use nylon strap to pull the pipe home
 - White markings on the spigot end will be visible on the bell's outside edge when the pipe is home
 - Hand shovel and knife in bedding to fill the bell hole
 - IMPROPER BELL HOLES SHOW ON THE INSIDE OF THE PIPE

- Welded joint assembly, if applicable
 - Lay bottom portion of the alignment band under joint location
 - Set pipe next to each other
 - Misalignment < 1/4"
 - Gap < 1 1/2"
 - Install valley gaskets (if using flow fill as backfill)
 - Install flat gasket (if using flow fill as backfill)
 - Assemble the rest of the alignment band
- Backfill requirements (refer to Contech project drawings or standard details)
 - 30" – 96": compacted ASTM D 2321 class I, II, or III
 - 108" & 120": compacted ASTM D 2321 class I
 - Flow fill (generally necessary around size on size tees, around large diameter manholes, deep manholes, refer to Contech project details.)
 - The use of native materials needs to be approved by the engineer (the use of native materials could negatively affect the structural capacity of the pipe and will be more difficult to install)
 - Special backfill or thrust blocks around manholes or fittings
 - Hand shovel or knife haunching material in place (regardless of material type)
 - 8" to 12" loose lifts
 - Compact to 90% standard proctor (light weight compaction equipment, such as a walk behind plate compactor, is recommended)
 - Maximum backfill height differential from one side of the pipe to the other is 12"
 - Use this method for entire initial backfill to minimum cover
- Anticipated construction loading
 - What are anticipated construction loads
- Preparation for welding crew
 - Projected date welders need to be on site
 - Crew there to weld joints only
 - Pipe must be dry
 - Pipe must be clean
 - Contractor to supply 1 person for hole watch
 - Contractor to supply ladder for ingress/egress, safety tripod, harnesses and leads if required
 - Actual number of days the project will take will be billed
 - Downtime caused by contractor will be billed (for example, no supplied ladder, hole watch or clean/dry pipe)
 - Backfilling is typically completed prior to welding operations begin
- Connecting to concrete manholes or other pipe
 - Lateral connection type
 - End to end connection type
 - Concrete manhole connection detail

- Thermal expansion and contraction
 - Backfill pipe quickly to overcome thermal expansion and contraction
- Joint testing
 - Type of testing required
 - Testing not performed by Contech
- Field modification and repairs
 - Same blade as used to cut DIP
 - 2' x 2' damaged area is not structural
 - Localized repair
 - Segmental pipe repair
- Manhole risers
 - Man holes are fabricated by using a 1' solid wall stub which a length of HDPE is slid over and then welded to. This makes the actual inside diameter less than stated on the drawings. For a 36" riser, the ID is actually closer to 32". (this is important if the contractor needs to fit mechanical/electrical components through the manholes)
- Items Contech is not delivering (typical estimate should include pipe & fabricated pieces, one of the jointing systems, freight)
 - Pumps, grinders, other mechanical
 - Power for anything
 - Floats and/or level indicators
 - Connections to inlet/outlet pipe
 - Air vents
 - Valves
 - Manhole lids and covers
 - Ladders
 - Engineering
 - Installation
 - Grout, backfill, etc
 - Flotation mitigation
 - Other _____

Notes: _____

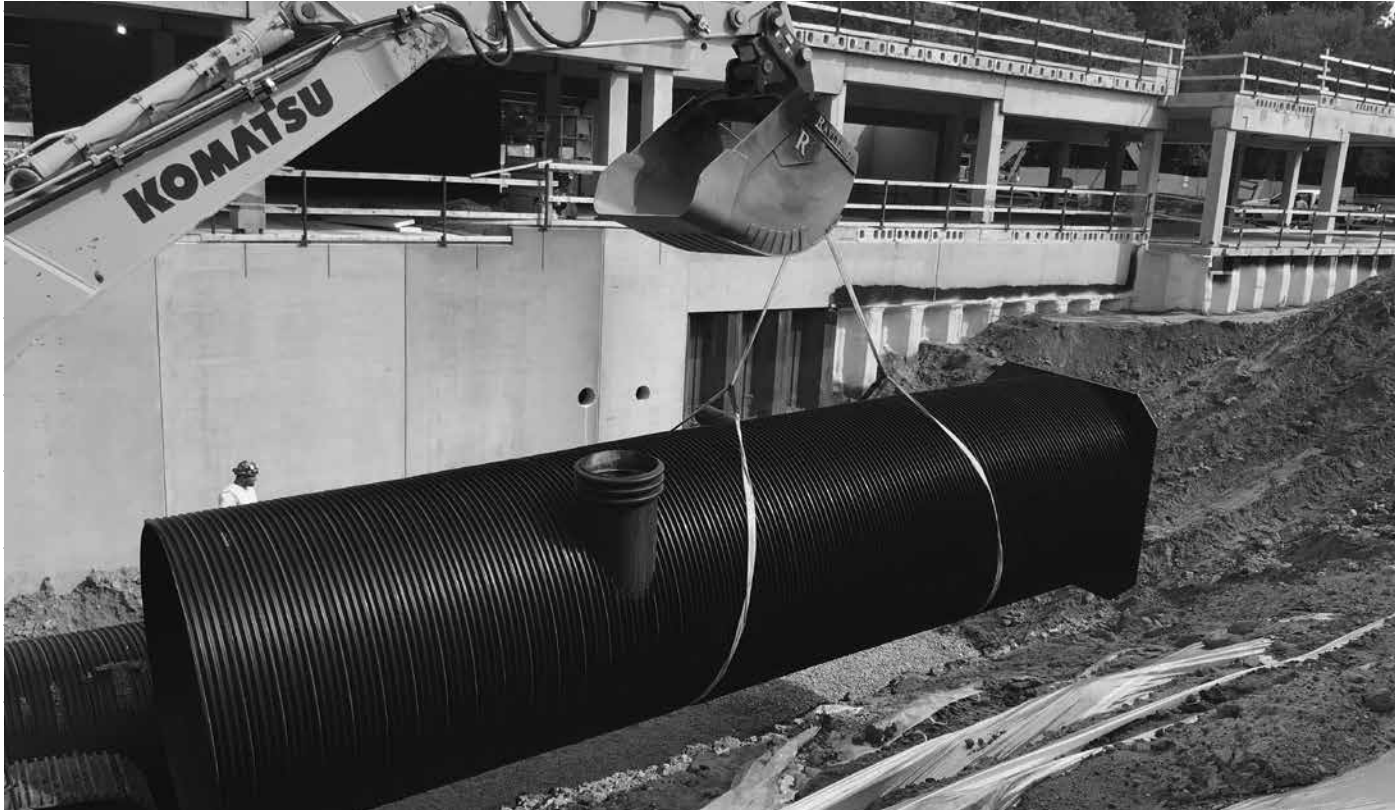

Notes:





CONTECH[®] ENGINEERED SOLUTIONS

© 2022 CONTECH ENGINEERED SOLUTIONS LLC, A QUIKRETE COMPANY

800-338-1122

www.ContechES.com

All Rights Reserved. Printed in the USA.

Contech Engineered Solutions LLC provides site solutions for the civil engineering industry. Contech's portfolio includes bridges, drainage, sanitary sewer, stormwater and earth stabilization products. For information on other Contech division offerings, visit ContechES.com or call 800-338-1122.

The product(s) described may be protected by one or more of the following US patents: 5,322,629; 5,624,576; 5,707,527; 5,759,415; 5,788,848; 5,985,157; 6,027,639; 6,350,374; 6,406,218; 6,641,720; 6,511,595; 6,649,048; 6,991,114; 6,998,038; 7,186,058; related foreign patents or other patents pending.

Support

Drawings and specifications are available at www.ContechES.com/cmp-detention

DMX Detention Install Guide 04/22

NOTHING IN THIS CATALOG SHOULD BE CONSTRUED AS A WARRANTY. APPLICATIONS SUGGESTED HEREIN ARE DESCRIBED ONLY TO HELP READERS MAKE THEIR OWN EVALUATIONS AND DECISIONS, AND ARE NEITHER GUARANTEES NOR WARRANTIES OF SUITABILITY FOR ANY APPLICATION. CONTECH MAKES NO WARRANTY WHATSOEVER, EXPRESS OR IMPLIED, RELATED TO THE APPLICATIONS, MATERIALS, COATINGS, OR PRODUCTS DISCUSSED HEREIN. ALL IMPLIED WARRANTIES OF MERCHANTABILITY AND ALL IMPLIED WARRANTIES OF FITNESS FOR ANY PARTICULAR PURPOSE ARE DISCLAIMED BY CONTECH. SEE CONTECH'S CONDITIONS OF SALE (AVAILABLE AT WWW.CONTECHES.COM/COS) FOR MORE INFORMATION.